

LCP Compact Foot/Compact Hand.

Technique Guide



Table of contents

Indications	2
LCP system description	3
Implants	5
Spezific instruments	8
Instruments overview	9
Surgical technique	10
Insertion of standards screws	12
Insertion of locking screws	14
Implant removal	16

 Image intensifier control

Warning

This description is not sufficient for immediate application of the instrumentation. Instruction by a surgeon experienced in handling this instrumentation is highly recommended.

Indications

Indications

LCP plates may in principle be used for the same indications as for the corresponding standard plates.

Thanks to the angular stability provided by the plate-screw connection, better clinical results can be obtained in patients with metaphyseal fractures, comminuted fractures and osteoporotic bone.

Possible indications for implants of size 2.0 and 2.4 include:

- Fractures of the phalanges
- Fractures of the metacarpals and metatarsals (II–V)
- Fractures of the distal radius (double-plate technique)
- Osteotomies and arthrodeses on the hand and foot (e.g. TMT [II–V] fusions)
- Subcapital radial head fracture
- As an additional implant with small fragments

Possible indications for implants of size 2.7 include:

- Fractures of metatarsal I
- Fractures of the tarsals
- MTP 1 fusions
- Osteotomies and arthrodeses of the tarsals (e.g. calcaneo-cuboidal fusion)

System description

The Combi-hole

The LCP (Locking Compression Plate) system offers the surgeon the choice, preoperatively and intraoperatively, of using either standard screws or locking screws – or a combination of the two screw types – for fracture fixation.

Experience in the use of LC-DCP or DCP plates or instruction by a surgeon with experience of their use is recommended.

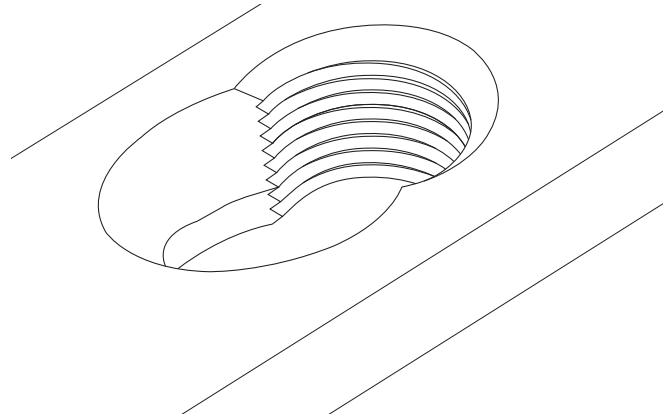

Tapered, threaded hole for locking screws (A)

The self-tapping locking screws can be locked in the tapered threaded hole to ensure angular stability. Plate and screw systems in which the screws are locked in the plate function according to the principle of an internal fixator and are used to resolve the following problem situations:

- Primary intraoperative loss of reduction
- Secondary postoperative loss of reduction, particularly in cases of osteoporosis or poor bone quality or of comminuted fractures without bony support
- Compression of the periosteum and the resulting impairment of cortical circulation

Note: To avoid the phenomenon of cold welding of plates and screws, we recommend the use of a screwdriver shaft with a mini quick coupling and appropriate handle (311.01X) or a torque limiter (511.77X).

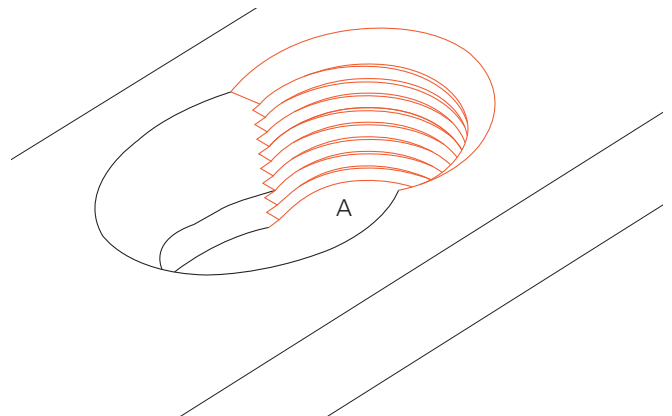

Functional principle of the internal fixator

When LCP plates are used with angularly stable locking screws, the plate and screws together form a stable system; the stability of the fracture is mainly dependent on the strength of the resulting assembly. Since the plate does not need to be compressed against the bone, blood flow to the bone is not additionally impaired.

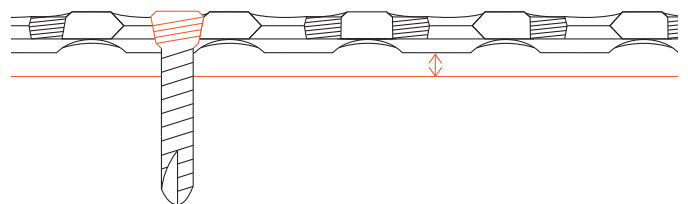

DC hole for standard screws (B)

The DC hole corresponds to the DCU (Dynamic Compression Unit) of the LC-DCP plate and is designed for standard cortex screws. As with any standard LC-DCP plate, axial compression of the fracture can be achieved by predrilling off-centre. Lag screws can also be angled laterally and longitudinally in relation to the plate for interfragmental compression. The DC hole is not suitable for the insertion of a locking screw.

Note: The standard screw must be placed first within a fragment in order to achieve compression.

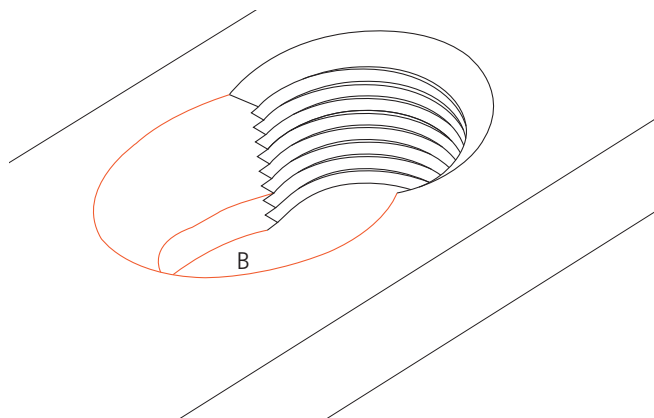

Functional principle of absolute stability

Securing the plate with standard screws creates friction between the underside of the plate and the surface of the bone by compression at the interface. In order to ensure absolute stability, the frictional resistance must be greater than the forces produced during rehabilitation. Bicortical screws are essential for this type of fixation.

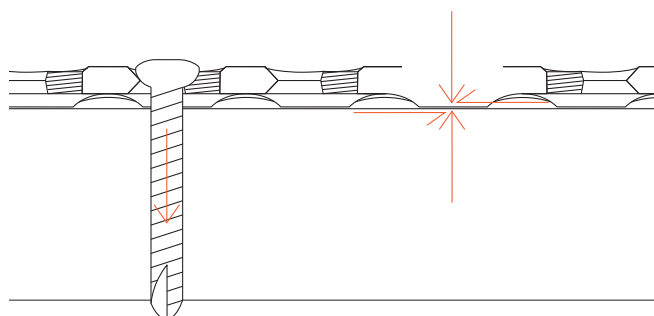

LCP 2.0 implants

Plates

LCP plate 2.0, straight, 4–8 holes (X47.344–348)



LCP T-plate 2.0 (X47.615)



LCP condylar plate 2.0 (X47.349)



LCP Y-adaption plate 2.0 (X47.350)



LCP T-adaption plate 2.0 (X47.351)



Standard screws

Cortex screws \varnothing 2.0 mm, self-tapping,
with Stardrive T6 (X01.356–381)



LCP locking screws

LCP locking screws \varnothing 2.0 mm, self-tapping,
with Stardrive T6 (X01.876–900)



LCP 2.4 implants

Plates

LCP plate 2.4, straight, 4–8 holes (X49.674–678)



LCP T-plate 2.4 (X49.615)



LCP condylar plate 2.4 (X49.679)



LCP Y-adaptation plate 2.4 (X49.669)



LCP T-adaptation plate 2.4 (X49.670)



Standard screws

Cortex screws \varnothing 2.4 mm, self-tapping,
with Stardrive T8 (X01.756–790)



LCP locking screws

LCP locking screws \varnothing 2.4 mm, self-tapping,
with Stardrive T8 (X12.806–830)



Buttress pin

Buttress pin 1.8 (head LCP 2.4),
with Stardrive T8 (400.190–193)



LCP 2.7 implants

Plates

LCP plate 2.7, straight, 4–7 holes (X49.680–683)



LCP condylar plate 2.7 (X49.684)



LCP T-plate 2.7 (X49.685, X49.697)



LCP L-plate 2.7, oblique (X49.686–687, X49.698–699)



LCP L-plate 2.7 (X49.688–689, X49.701–702)

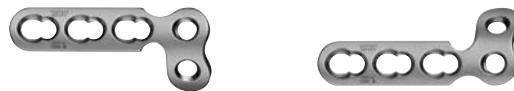

H-locking plate 2.7 (X49.690–691)



Standard screws

Cortex screws \varnothing 2.7 mm, self-tapping,
with Stardrive T8 (X02.866–900; X02.965–969)



LCP locking screws

LCP locking screws \varnothing 2.7 mm (head 2.4 mm),
self-tapping, with Stardrive (X02.206–240)

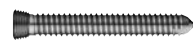

Specific instruments

Bending instruments

Bending pin for LCP plates 2.0 (329.921)

Bending pin for LCP plates 2.4 and 2.7 (329.922)



Drill sleeves

LCP drill sleeve 2.0, with scale, for drill bits \varnothing 1.5 mm (323.034)

LCP drill sleeve 2.4, with scale, for drill bits \varnothing 1.8 mm (323.029)

LCP drill sleeve 2.7, with scale, for drill bits \varnothing 2.0 mm (323.033)



Drills

Drill bit \varnothing 1.5 mm, with marking, length 96 mm, 2-flute, for mini quick coupling (310.507)

Drill bit \varnothing 1.8 mm, with marking, length 96 mm, 2-flute, for mini quick coupling (310.508)

Drill bit \varnothing 2.0 mm, with marking, length 110 mm, 2-flute, for quick coupling (310.534)



Screwdriver shafts

Screwdriver shaft Stardrive 2.0, short/long, self-holding, for mini quick coupling (313.842/843)

Screwdriver shaft Stardrive 2.4/2.7, short/long, self-holding, for mini quick coupling (314.451/452)



Torque limiter

Torque limiter for screws 2.0, with mini quick coupling (0.4 Nm) (511.777)

Torque limiter for screws 2.4 and 2.7, with AO/ASIF quick coupling (0.8 Nm) (511.776)



Instrument overview

Art. No.	Article name	2.0	2.4	2.7
391.951	Cutting pliers for plates 1.0 to 2.4	•	•	•
329.921	Bending pins for LCP plates 2.0	•		
329.922	Bending pins for LCP plates 2.4/2.7		•	•
347.901	Flat-nosed pliers, pointed, for plates 1.0 to 2.4	•	•	
391.963	Universal bending pliers, length 165 mm			•
323.200	Universal drill sleeve 2.0	•		
323.202	Universal drill sleeve 2.4		•	
323.260	Universal drill sleeve 2.7			•
323.034	LCP drill sleeve 2.0 with scale, for drill bits \varnothing 1.5 mm	•		
323.029	LCP drill sleeve 2.4 with scale, for drill bits \varnothing 1.8 mm		•	
323.033	LCP drill sleeve 2.7 with scale, for drill bits \varnothing 2.0 mm			•
310.507	Drill bit \varnothing 1.5 mm, with marking for mini quick coupling	•		
310.508	Drill bit \varnothing 1.8 mm, with marking for mini quick coupling		•	
310.534	Drill bit \varnothing 2.0 mm, with marking for AO/ASIF quick coupling			•
319.005	Depth gauge for screws 2.0 and 2.4	•	•	
319.010	Depth gauge for screws 2.7			•
313.842/843	Screwdriver shaft Stardrive T6, 2.0, short/long	•		
314.451/452	Screwdriver shaft Stardrive T8, 2.4, short/long		•	•
511.777	Torque limiter 2.0, with mini quick coupling (0.4 Nm)	•		
511.776	Torque limiter 2.4/2.7, with AO/ASIF quick coupling (0.8 Nm)		•	•

Surgical technique

The following surgical technique is described using the example of an LCP T-plate 2.0. Implant handling is identical for the sizes 2.0, 2.4 and 2.7.

The article numbers for the required instruments are listed in the table on page 9. The instruments are colour-coded as follows: 2.0 blue, 2.4 violet, 2.7 orange. These instruments are identified in the text by an asterisk (*).

1

Reduce fracture

- ① Reduce the fracture under the image intensifier and, if necessary, fix with Kirschner wires or reduction forceps.

2

Trim plate

Trim plate to the desired length using the cutting pliers* and remove the burrs.

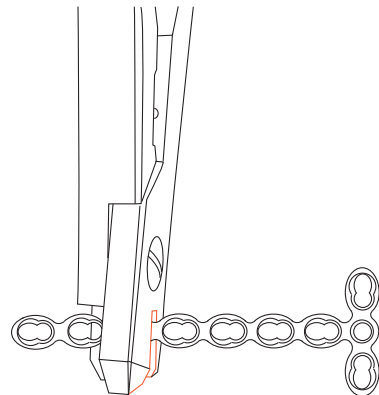

3

Bend plate

Bend the plate using the flat-nosed pliers*. The bending pins* can be used to bend the round threaded holes.

Note: If possible, bend the plate between the combi-holes. Do not deform the combi-holes during bending as this may hinder the subsequent insertion of locking screws.

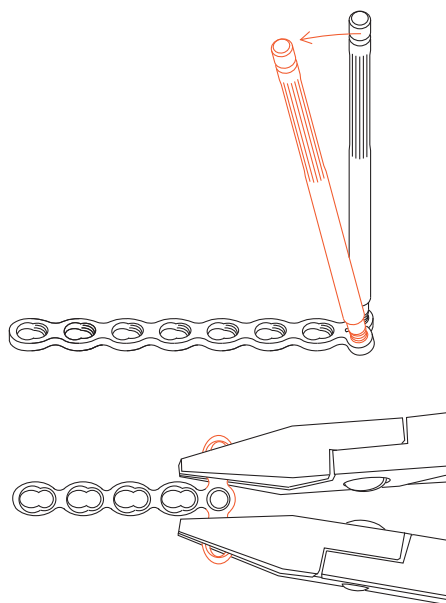

4

Position plate

Position the plate over the reduced fracture and, if necessary, fix provisionally with Kirschner wires or reduction forceps.

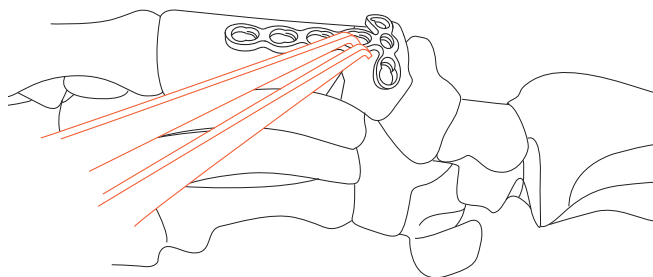

5

Determine screw type

Depending on the indication and situation in each case, standard screws and/or LCP locking screws may be inserted. If both cortex and locking screws are used in one plate, the cortex screws must be inserted first in order to compress the plate against the bone before the locking screws are inserted.

Note: If angularly-stable buttress pins are used, one screw per bone fragment must be inserted additionally.

Insertion of standard screws

6a

Predrill screw hole

- Using the universal drill sleeve*, predrill the screw hole either neutrally or off-centre.

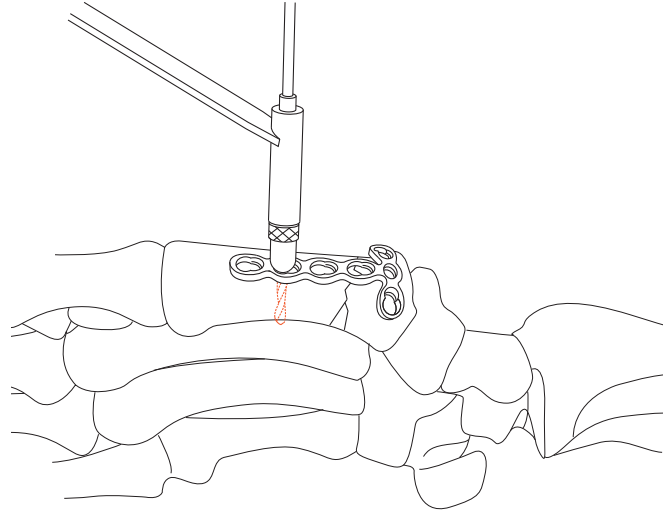

6b

Determine screw length

- Determine the screw length with the depth gauge*.

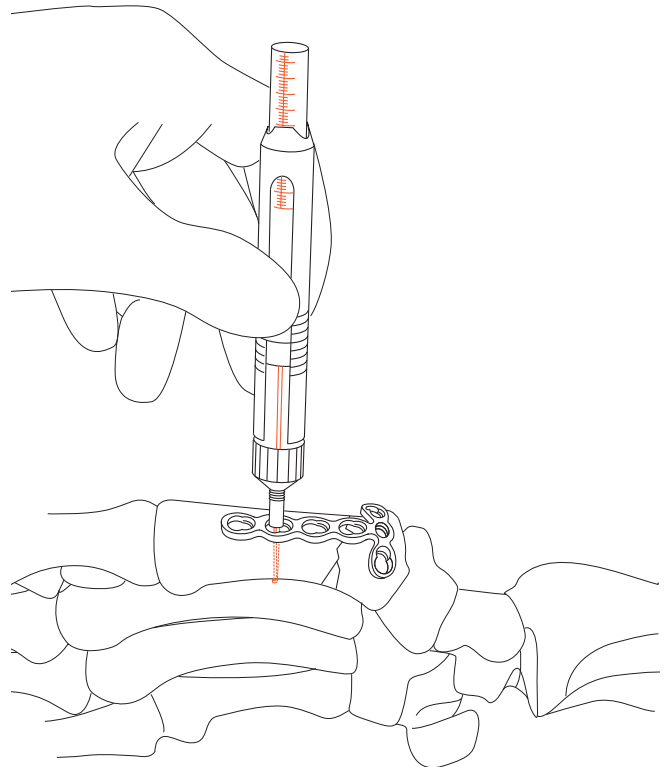

6c

Pick up screw

Select and pick up the matching screw using the Stardrive screwdriver shaft* and appropriate handle (311.01X).

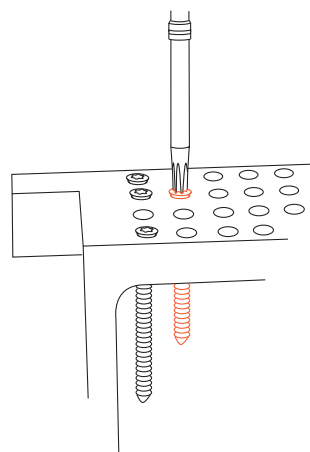
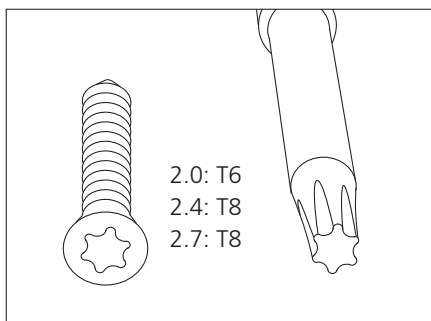

6d

Insert standard screw

Insert self-tapping standard screw either neutrally or off-centre.

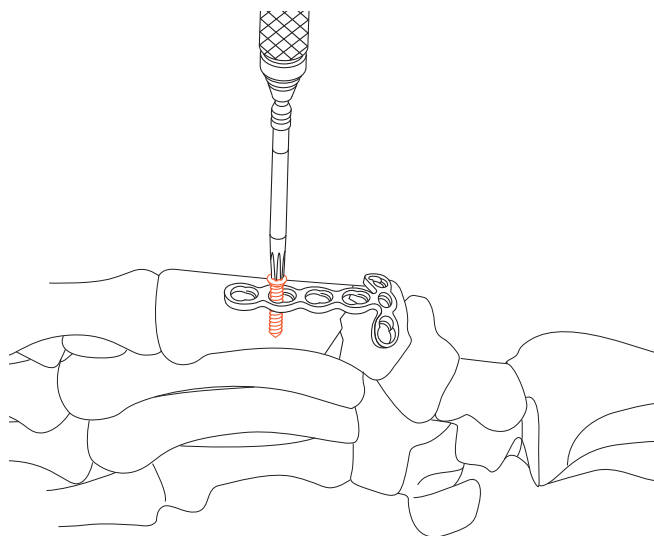

6e

Insert additional standard screws

Insert additional standard screws depending on the corresponding indication and situation.

Insertion of locking screws

7a

Insert LCP drill sleeve

Screw the LCP drill sleeve* into the desired plate hole at right angles to the plate.

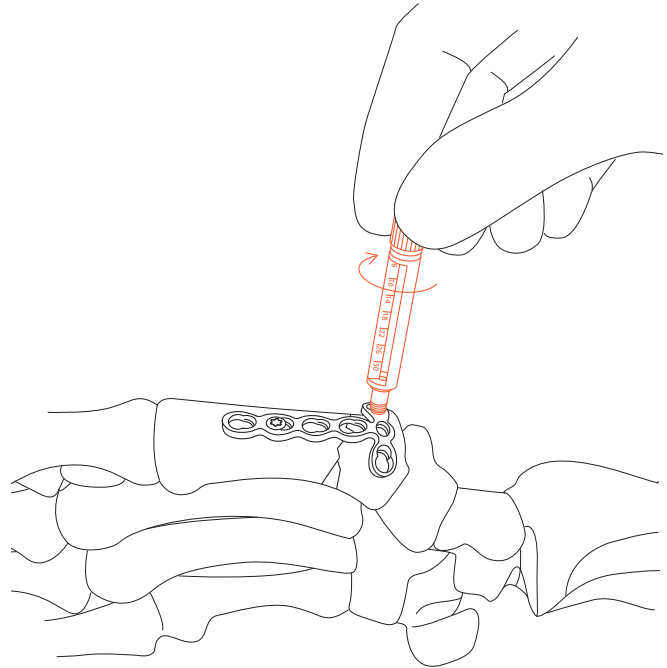

7b

Predrill screw hole and determine screw length

 Pre-drill screw hole through the LCP drill sleeve* using the appropriately sized drill bit with marking*. Read off the screw length directly on the scale of the drill sleeve. Then remove the drill sleeve.

Alternatively, the screw length can be determined using the depth gauge*.

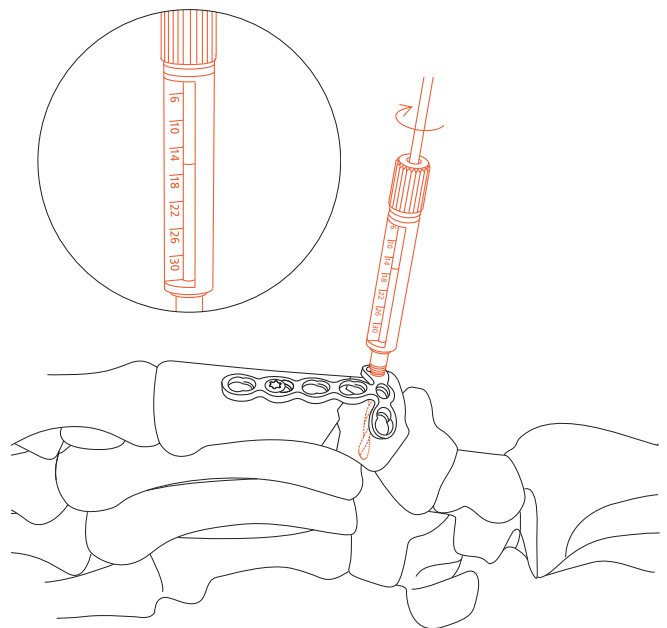

7c

Pick up screw

Select and pick up the matching screw using the self-holding Stardrive screwdriver shaft* and the appropriate handle (311.01X).

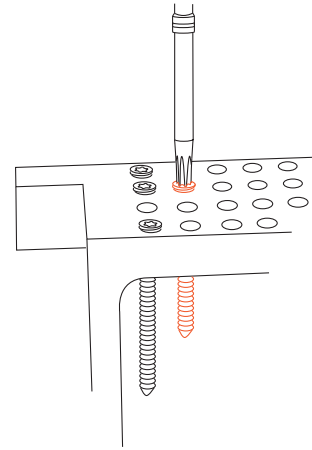
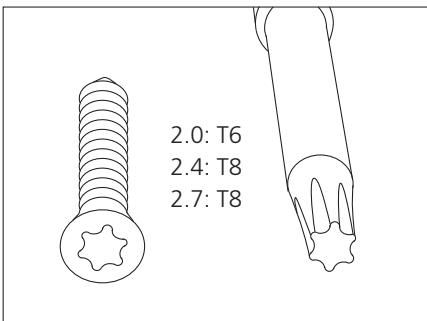

7d

Insert self-tapping locking screw

- For manual insertion of LCP locking screws, use the self-holding Stardrive screwdriver shaft and the appropriate handle (311.01X).
- For mechanical insertion of LCP locking screws 2.7* (head LCP 2.4), attach the 0.8 nm torque limiter* to the Colibri drive unit (532.001). Insert the Stardrive 2.4/2.7 screwdriver shaft* into the torque limiter and pick up the LCP locking screw. To insert the screw, start the drive unit slowly, increase the speed and then reduce again before the screw is fully tightened. The torque is automatically limited and a clearly audible clicking signifies that the torque limit has been reached. Stop the drive unit and disconnect from the screw.

Note: Overtightening the LCP screws can cause thread deformation, making subsequent screw removal impossible. We therefore recommend the use of a screwdriver shaft with a mini quick coupling and appropriate handle (311.01X) or a torque limiter (511.77X).

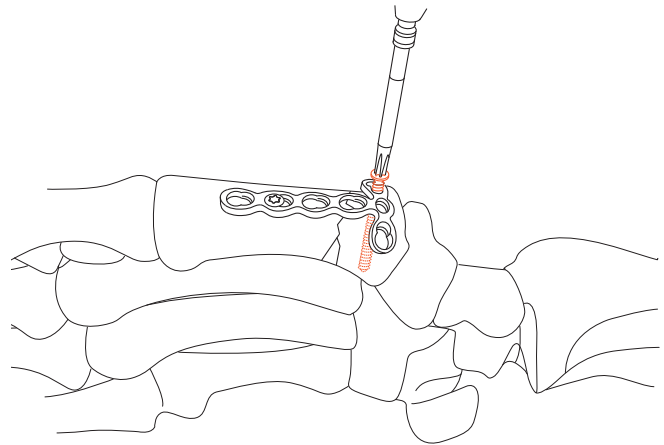

7e

Insert additional locking screws

Insert additional locking screws depending on the indication and situation.

Implant removal

8

Remove implants

To remove the plate, first unlock all screws then definitively remove them in a second step, otherwise the plate may rotate while the last screw is being removed and cause soft tissue damage.



Synthes GmbH
Eimattstrasse 3
CH-4436 Oberdorf
www.synthes.com

Presented by:



CE
0123

036.000.114 SE_053705-AA 31060016 © Synthes 2006 Printed in Switzerland Subject to modifications.